

SERIES 2000



EXTREMELY HEAVY DUTY SLIDING SYSTEMS





# Heavy objects need heavy solutions

Series 2000 is a multifunctional solution designed for straight sliding systems with loads up to 2000 kg. This top-hung system is unique in its weight class enabling extremely large doors and heavy objects to be moved easily.

This extremely durable series is typically used to cover very large door openings, for example in the marine industry, aircraft hangars, warehouse facilities, exhibition halls and logistic centers for truck loading bays. High quality hot-dipped galvanized steel track along with other top class components are suitable for both indoor and outdoor use.

The thick and sturdy, yet compact track and hanger design enables large door areas and moving heavy loads without compromising safety or operational lightness. Our durable and reliable systems are maintenance free and will last a lifetime.

## Weight class

This top-hung and high weight capacity system is immediately available from Helaform's extensive stock facilities.

The heaviest doors slide easily when you use the Helaform hangers that include permanently lubricated precision ball bearings together with our durable galvanized K-2000 track.

## Unique solutions

Special components suitable for this series can also be manufactured according to the customer's needs and applications. We also have vast experience for using this series for applications other than doors, such as in the mining industry, overhead conveyors and crane systems.

Please contact our sales department to find a solution for your project requirements!

” Top-hung system for capacities up to 2000 kg

Hot-dipped galvanized steel track together with steel wheels offer a durable solution for the heaviest projects.

## Application examples

- » Aircraft hangars
- » Tires and depot storages
- » Harbors and docks
- » Big storages
- » Extremely heavy conveyor systems



Series 2000  
Datasheet

## Specifications

<b>Weight</b> (max. capacity)	2000 kg
<b>Door size</b> (max. in exterior use)	* Over 40 m <sup>2</sup>
<b>Door material</b>	Metal
<b>Bracket interval</b> (max.)	1000 mm

\* Contact our sales if the door size exceeds 40 m<sup>2</sup>



Hangers with steel wheels.  
Lubricated for life precision ball bearings.  
Guiding ball bearings.



Hot-dipped galvanized track (70 µm).



Zinc plated (min. 8 µm) steel parts. Tested  
in salt water spray chamber (240 h).



## Installation examples

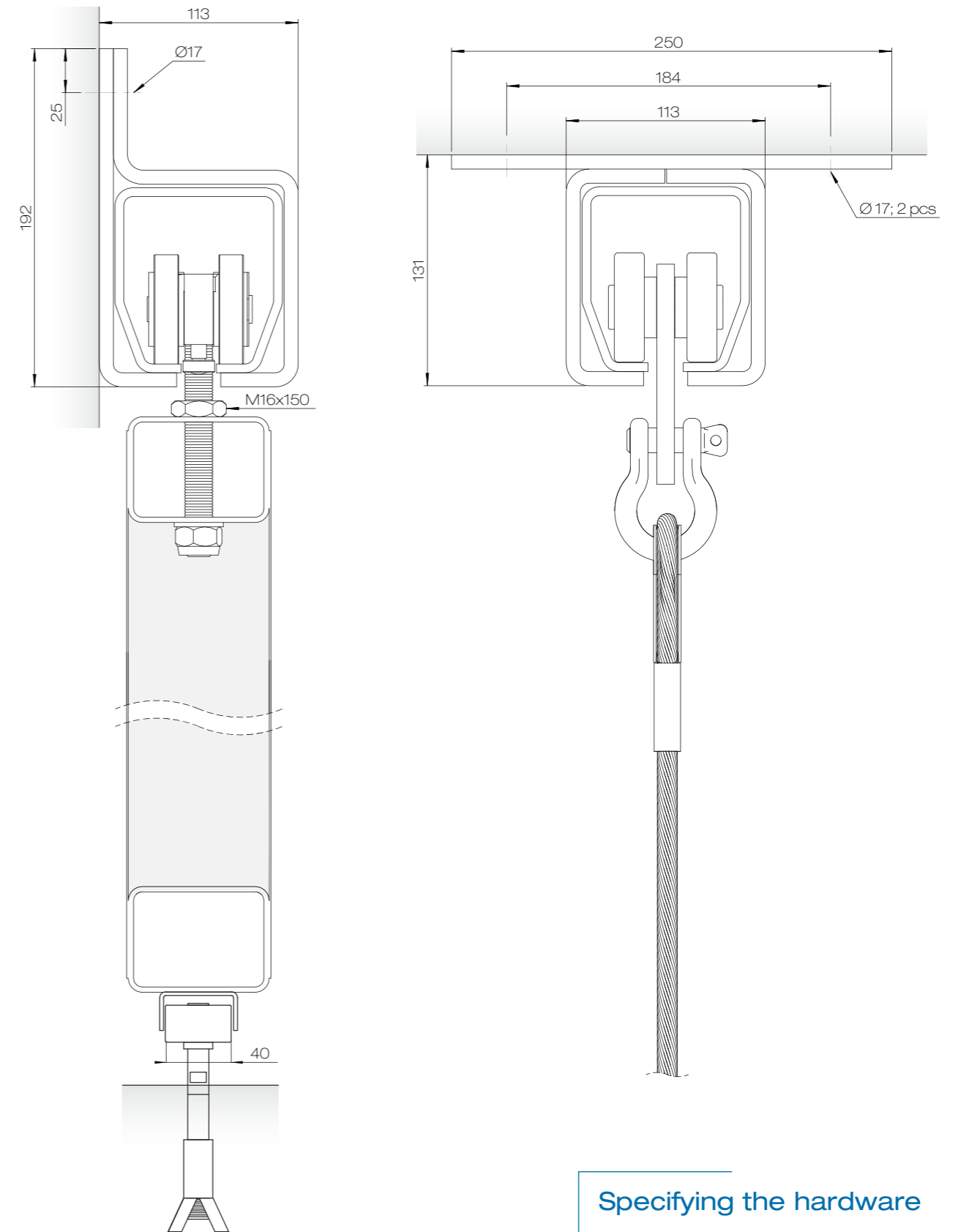

*NOTE! The required bottom guide solution depends highly of the installation scene and door setup.*

### Specifying the hardware

- » Hangers are installed 2 pcs / door
- » Track length is normally twice the width of the door opening
- » Number of brackets = length of track (m) + 1 pcs
- » It's necessary to install joints or joint brackets at all track joints
- » Bottom guides must be used with door installations
- » Exterior installations require separate wind hatches or equivalent to be used against extensive wind loads



Top hung bi-parting storage bay doors enable ease of logistics in a Swedish warehouse complex.

## Products and codes

Galvanized steel track			Code
	K-2000	6 m	60016
Hangers			
	MP-2000	For metal doors, steel wheels	60040
	KV-2000 (Capacity 1000 kg/pc)	For applications, steel wheels	60042
Wall brackets			
	SKL-2000	Joint bracket	60070
Soffit brackets			
	KKKL-2000	Joint bracket	60080
	KKL-2000 M16 x 160	Joint bracket, with bolt	60090
Accessories			
	Stop P	Wall stop	50111
	KP-2000	Track stop	60110

- » Joint brackets include screws for tightening the bracket to the track. Joint brackets can also be used for track joints.
- » Bottom guide options are presented in a separate datasheet.
- » 3D models, DWG and PDF drawings of the specific items can be found on our web page.

# Reference



Swissport's large storage facilities with extremely heavy doors on Helaform sliding hardware permit large loading bays at the new Ghana Airport.

## Company information

Helaform is a Finnish, family owned company manufacturing sliding and folding door systems with capacities up to 2000 kg. With over 30 years of experience Helaform is one of the world's leading suppliers of sliding and folding door systems.

Helaform's product range covers modern architectural and industrial applications as well as ecological enhancements, such as greenhouse plant watering systems.

