

helaform®

SERIES 300/500



HEAVY DUTY SLIDING SYSTEMS

300
-
1200
kg



↖ Helaform's MPS hangers have a unique design feature that allows the doors to be easily lifted up and hooked onto the hangers, with simple height adjustment afterwards.

Series for heavy duty projects

Series 300/500 is a durable and versatile system for heavy duty industrial and agricultural sliding doors and applications. The track profile and hanger design makes it a unique solution to move heavy loads extremely lightly while securing lifelong functionality.

These heavy capacity products made from high quality steel are typically used in industrial buildings and storage complexes, as well as in interior solutions for public buildings to cover large partitions like fire doors. In addition to sliding door systems the products can also be used in a variety of other applications such as conveyor systems and art museum storage solutions.

Precision manufacturing and thoughtfully designed products allows ease of installation and maintenance free use.

Versatile possibilities

The series has been engineered so that it occupies the minimum space whilst supporting heavy duty weights. The series is based on two track sizes, with all the accessories used for both track sizes.

The track determines the maximum weight capacity per door, so by changing the track you can easily increase the loading capacity; track K-300 is up to 300 kg and track K-500 is up to 500 kg.

” Solutions for heavy industrial sliding systems

However with special high capacity MPT hangers the weight capacity can be increased to 1200 kg.

This flexibility of the series and high range of accessories to choose from, permits a large variety of options when planning sliding applications for different projects.

Application examples

- » Industrial buildings
- » Storages and warehouses
- » Fire doors
- » Conveyor systems
- » Museum storage solutions



Series 300/500
Datasheet

Specifications

	300 Series	500 Series	500 Series*
Weight (max. capacity)	300 kg	500 kg	1200 kg
Door size (max. in exterior use)	~ 25 m ²	~ 30 m ²	~ 40 m ²
Door material	Wood/Metal	Wood/Metal	Metal
Track	K-300	K-500	K-500
Bracket interval (max.)	1000 mm	1000 mm	500 mm

* Use hanger IMPT-600 to achieve 1200 kg max. weight capacity.

-  Hangers with nylon or steel wheels.
Lubricated for life ball bearings.
-  Hot-dipped galvanized track (20 µm).
-  Zinc plated (min. 8 µm) steel parts. Tested in salt water spray chamber (240 h).



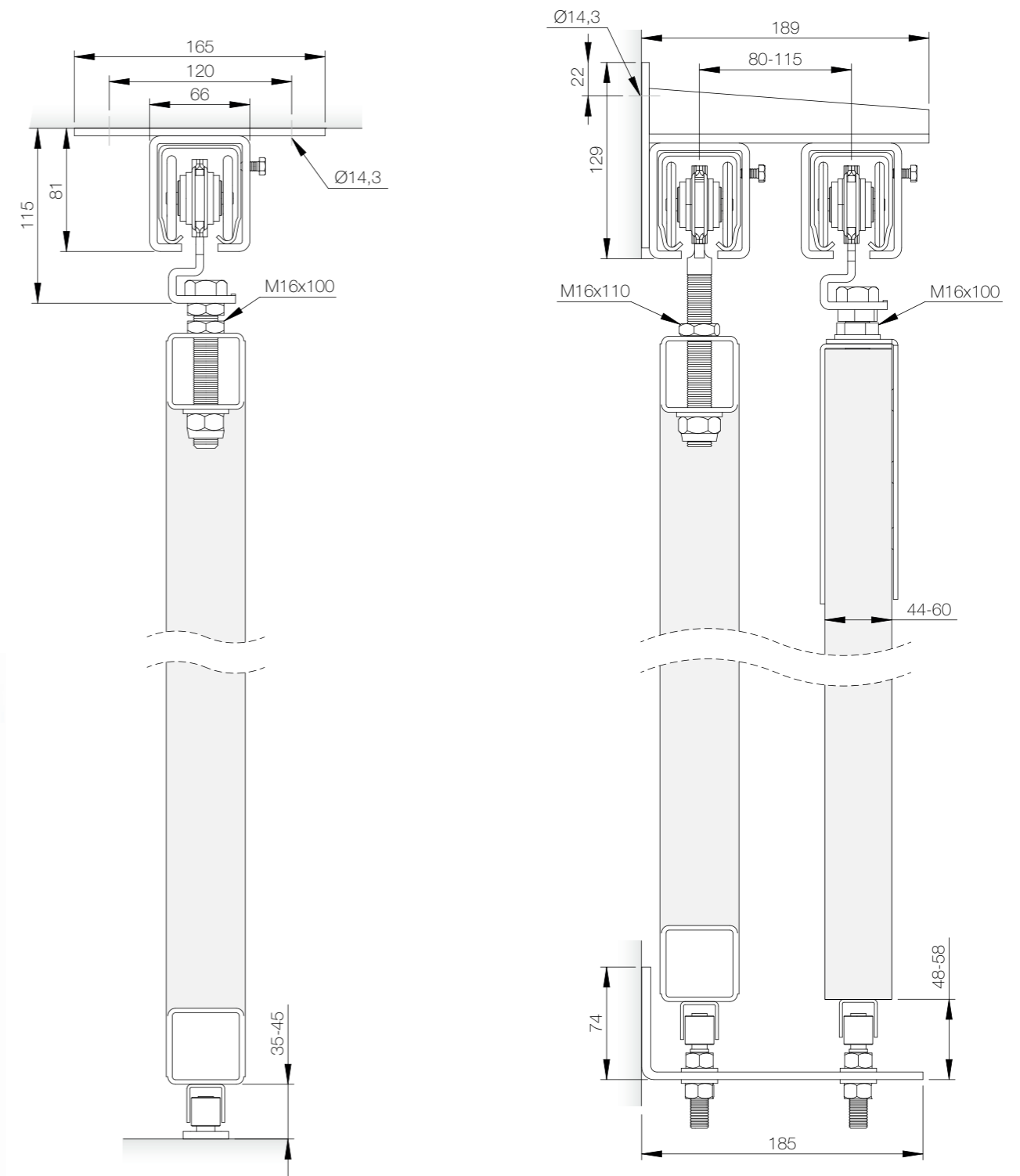

Installation examples







Specifying the hardware

- » Hangers are installed 2 pcs/door
- » Track length is normally twice the width of the door opening
- » Number of brackets = length of track (m) + 1 pcs
- » It's necessary to install joints or joint brackets at all track joints
- » Bottom guides must be used with door installations
- » In exterior installations, please note the wind loads



Products and codes



Galvanized steel track (capacity 300 kg)			Code
	K-300	2 m	50012
		3 m	50013
		4 m	50014
		5 m	50015
		6 m	50016
	K-300 90°	Curve 90° R=600 (only for 2-wheel hangers, KV-300/500 and KVLP-300/500)	50033







Galvanized steel track (capacity 500 kg)			Code
	K-500	2 m	50022
		3 m	50023
		4 m	50024
		5 m	50025
		6 m	50026









Hangers			
	MPS-300/500 (Capacity 500 kg/pair)	Steel wheels	50040
		Steel wheels, heat resistance (300°C)	50054
		Nylon wheels	50058
	MP-300/500 (Capacity 500 kg/pair)	Steel wheels	50044
		Steel wheels, with 200 mm bolt	50050
		Nylon wheels	50057
	MPT-600 (Capacity 1200 kg/pair)	Steel wheels	50055

Hangers with fixing plates			
	PPS-300/500 (Capacity 500 kg/pair)	Steel wheels, with side fixing plates	50041
	PP-300/500 (Capacity 500 kg/pair)	Steel wheels, with side fixing plates	50045

Hangers for applications			
	POP-300/500 (Capacity depends on application)	Steel wheels, hanger for curtain	50051
	KVLP-300/500 (Capacity depends on application)	Steel wheels	50063
	KV-300/500 (Capacity depends on application)	Steel wheels	50064

Wall brackets			
	SK-300/500	Bracket	50070
	SKL-300/500	Joint bracket	50071
	SK-300/500	Double bracket	50074
	SKL-300/500	Double joint bracket	50075

Soffit brackets			
	KK-300/500	Bracket	50080
		Bracket, for welding	50082
	KKL-300/500	Joint bracket	50081
		Joint bracket, for welding	50083
	KKK-300/500	Bracket	50084
	KKKL-300/500	Joint bracket	50085
	KKK/2-300/500	Double bracket	50086
	KKKL/2-300/500	Double joint bracket	50087
	KK-300/500/12 x 100	Bracket, with timber screw	50088
	KKL-300/500/12 x 100	Joint bracket, with timber screw	50089
	KK-300/500/M12 x 50	Bracket, with bolt	50099
	KKL-300/500/M12 x 50	Joint bracket, with bolt	50103
	KK-300/500/M12 x 120	Bracket, with bolt	50090
	KKL-300/500/M12 x 120	Joint bracket, with bolt	50091

Accessories			
	LKU-300/500/200 mm	Joint	50092
	PLS-300/500	Plates for timber door, side fixing	50100
	PLS-300/500/ E	Plates for timber door, side fixing	50101
	PLP-300/500, M16 x 140	Plate for timber door, top fixing	50102
	KP-300/500	Track stop	50110
	Stop P	Wall stop	50111
	PK-300/500	End plate	50120
	S-50/5.5 mm	S-hook	20400

- ▶ Joint brackets include screws for tightening the bracket to the track. Joint brackets can also be used for track joints.
- ▶ Bottom guide options are presented in a separate datasheet.
- ▶ 3D models, DWG and PDF drawings of the specific items can be found on our web page.

Reference



↖ The Helaform's 300 Series slides cafeteria's burglary protections at Helsinki-Vantaa airport.

Company information

Helaform is a Finnish, family owned company manufacturing sliding and folding door systems with capacities up to 2000 kg. With over 30 years of experience Helaform is one of the world's leading suppliers of sliding and folding door systems.

Helaform's product range covers modern architectural and industrial applications as well as ecological enhancements, such as greenhouse plant watering systems.

